

MaxiLED
Lighting



MaxiGOBO 400

Distributed by AMLUX srl, 46042, Castel Gubbio (MC) - info@amlux.it - www.amlux.it

MaxiGOBO 400



Precision Projection, Built to Endure

The **MaxiGOBO 400** is a robust, weather-resistant gobo projector engineered for high-impact outdoor and indoor visual displays.

Housed in a high-strength aluminum alloy body with IP65-rated protection, it's built to withstand the toughest environments while delivering crisp, vibrant imagery.

Equipped with a 6-pattern gobo wheel, electronic linear focus, and motorized zoom from 10° to 50°, the **MG-400** offers remarkable flexibility and creative control. Its intuitive swivel bracket allows for fast, versatile mounting, making it ideal for architectural lighting, branding projections, or immersive scenic effects.



MaxiGOBO 400

Specifications

Working Voltage : **AC110-240V**

Power : **400W**

Electrical Shock Protection : **Class I**

Control Protocol: **DMX512, Auto**

Light Source: **LED**

Color Temperature : **7500K**

Beam Angle : **10° ~ 50° zoom automatic**

Effect: **6 rotating full-colour gobos**

Housing : **Aluminium**

Installation : **Bracket**

Weight : **15 kg**

IP Rated : **IP65**

Life: **> 40000 hrs**

Efficiency: **≥ 30lm/w**

Channels: **10**

Certification: **CE.ROHS**

Features



Finishes



Dimensions (mm)

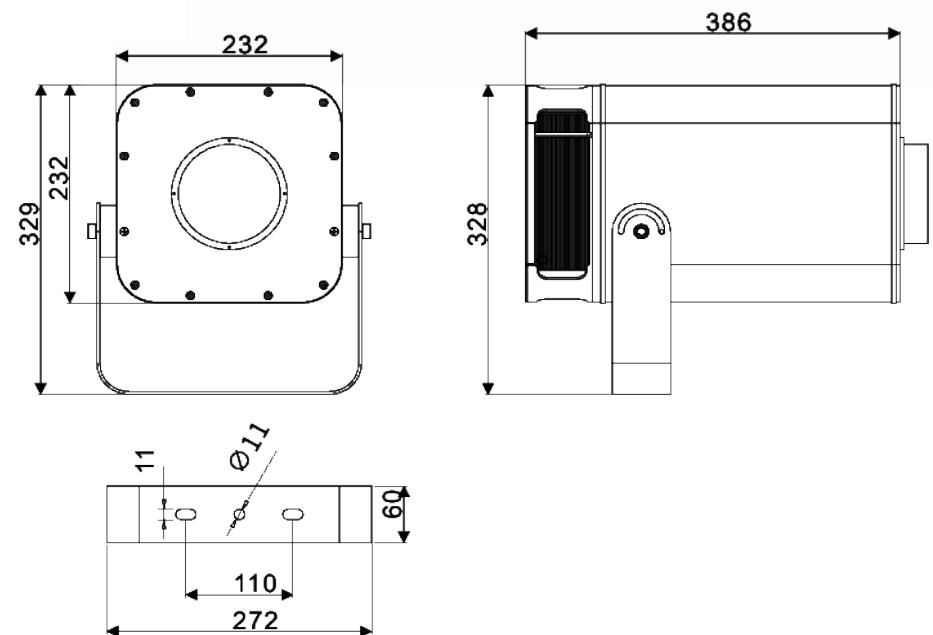

Gobos size (mm)

OD: 25.8

ID : 20

Thickness : 2.2



Dynamic effect

Optional

MaxiLED
Lighting

MaxiGOBO

Channels (DMX 512 Configuration)

Channel	Function	Value	Description
Ch 1	Strobe	0 - 7	Turn off
		4 - 75	Strobe 1
		76 - 145	Strobe 2
		146 - 215	Strobe 3
		216 - 255	Turn on
Ch 2	Dimmer	0 - 255	Linear dimmer
Ch 3	Gobo rotation	0 - 9	Gobo 1
		10 - 19	Gobo 2
		20 - 29	Gobo 3
		30 - 39	Gobo 4
		40 - 49	Gobo 5
		50 - 59	Gobo 6
		60 - 69	Gobo 1 shake slow to fast
		70 - 79	Gobo 2 shake slow to fast
		80 - 89	Gobo 3 shake slow to fast
		90 - 99	Gobo 4 shake slow to fast
		100 - 109	Gobo 5 shake slow to fast
		110 - 119	Gobo 6 shake slow to fast
		120 - 149	From fast to slow positive flow
		150 - 179	From slow to fast reverse flow
		180 - 217	Dwell time from fast to slow positive flow
218 - 255	Dwell time from slow to fast reverse flow		
Ch 4	Gobo Auto-rotation	0 - 127	0 - 360°
		128 - 190	From fast to slow positive flow
		191 - 192	Stop
		193 - 255	From slow to fast reverse flow
Ch 5	Auto-rotation Fine	0 - 255	/
Ch 6	Zoom	0 - 255	From large to small
Ch 7	Zoom fine	0 - 255	From large to small
Ch 8	Focus	0 - 255	From far to near
Ch 9	Focus fine	0 - 255	From far to near
Ch 10	Reset	200 - 209	Reset all motors in more than 6 seconds

Certifications



MaxiLED
Lighting

MaxiGOBO 400



MaxiGOBO Projector

Unit 2, Farrington Place, Rossendale Road Ind. Est. Burnley, Lancashire. UK. BB11 5TY
T: +39 347 5911784 E: sales@maxigoboprojector.com Web: www.maxigoboprojector.com

Distributed by AMLUX srl, 46042, Castel Goffredo (MN), info@amlux.it, www.amlux.it