

MaxiLED
Lighting



MaxiGOBO 600

Distributed by AMLUX srl, 46042, Castel Goffredo (MN), info@amlux.it, www.amlux.it

MaxiGOBO 600



Power Meets Precision

Engineered for demanding lighting applications, the **MaxiGOBO 600** delivers exceptional brightness and sharpness in any environment. With a rugged IP65 - rated aluminum housing, it's ready for permanent outdoor installations or indoor scenography where reliability is paramount.

This **600W** powerhouse features a 6-pattern rotating gobo wheel, electronic linear focus, and motorized zoom from 10° to 50°, allowing for dynamic, high-definition projections with ease. Its quick-mount swivel bracket ensures fast setup and precise alignment - perfect for architectural mapping, themed attractions, and brand displays.



MaxiGOBO 600

Specifications

Working Voltage : **AC110-240V**

Power : **600W**

Electrical Shock Protection : **Class I**

Control Protocol: **DMX512, Auto**

Light Source: **LED**

Color Temperature : **7500K**

Beam Angle : **10° ~ 50° zoom automatic**

Effect: **6 rotating full-colour gobos**

Housing : **Aluminium**

Installation : **Bracket**

Weight : **21 kg**

IP Rated : **IP65**

Life: **> 40000 hrs**

Efficiency: **≥ 30lm/w**

Channel: **10**

Certification: **CE,ROHS**

Features



Finishes



Dimensions (mm)

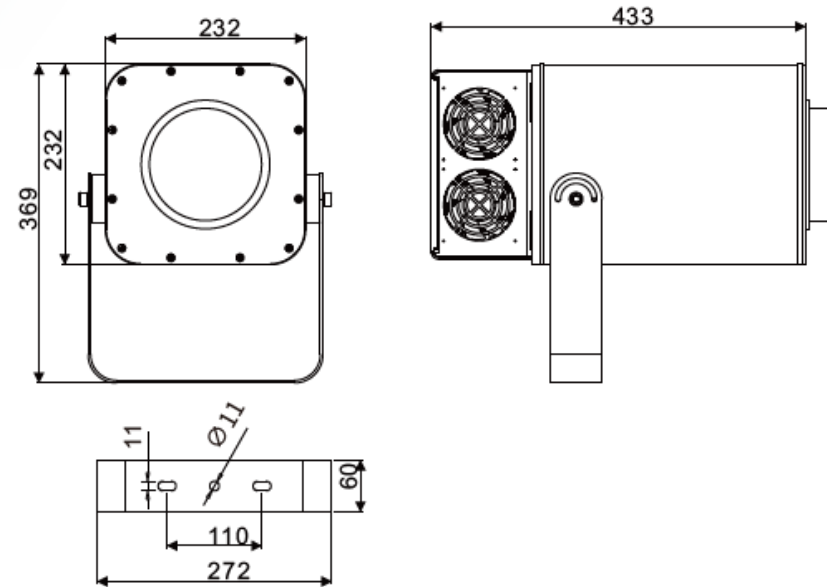

Gobos size (mm)

OD: 25.8

ID : 20

Thickness : 2.2

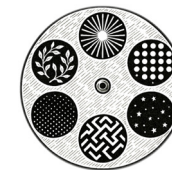

Dynamic effect

Optional

MaxiLED
Lighting

MaxiGOBO

Channels (DMX 512 Configuration)

Channel	Function	Value	Description
Ch 1	Strobe	0 - 7	Turn off
		4 - 75	Strobe 1
		76 - 145	Strobe 2
		146 - 215	Strobe 3
		216 - 255	Turn on
Ch 2	Dimmer	0 - 255	Linear dimmer
Ch 3	Gobo rotation	0 - 9	Gobo 1
		10 - 19	Gobo 2
		20 - 29	Gobo 3
		30 - 39	Gobo 4
		40 - 49	Gobo 5
		50 - 59	Gobo 6
		60 - 69	Gobo 1 shake slow to fast
		70 - 79	Gobo 2 shake slow to fast
		80 - 89	Gobo 3 shake slow to fast
		90 - 99	Gobo 4 shake slow to fast
		100 - 109	Gobo 5 shake slow to fast
		110 - 119	Gobo 6 shake slow to fast
		120 - 149	From fast to slow positive flow
		150 - 179	From slow to fast reverse flow
		180 - 217	Dwell time from fast to slow positive flow
218 - 255	Dwell time from slow to fast reverse flow		
Ch 4	Gobo Auto-rotation	0 - 127	0 - 360°
		128 - 190	From fast to slow positive flow
		191 - 192	Stop
		193 - 255	From slow to fast reverse flow
Ch 5	Auto-rotation Fine	0 - 255	/
Ch 6	Zoom	0 - 255	From large to small
Ch 7	Zoom fine	0 - 255	From large to small
Ch 8	Focus	0 - 255	From far to near
Ch 9	Focus fine	0 - 255	From far to near
Ch 10	Reset	200 - 209	Reset all motors in more than 6 seconds

Certifications



MaxiGOBO 600



MaxiGOBO Projector

Unit 2, Farrington Place, Rossendale Road Ind. Est. Burnley, Lancashire. UK. BB11 5TY
T: +39 347 5911784 E: sales@maxigoboprojector.com Web: www.maxigoboprojector.com

Distributed by AMLUX srl, 46042, Castel Goffredo (MN), info@amlux.it, www.amlux.it